

MiniDos

Operating Manual • Mode D'Emploi
Bedienungs Handbuch • Manual de Operación
Manual de operação • Manuale d'uso



Model 0.4%
Model 0.4% PAA
Model 1%
Model 2.5%
Model 5%
Model 10%
Model 20%

Fluid Flow Range:

Débit d'eau:

Durchflussmenge:

Caudal de trabajo:

Vazão Operativa:

Velocità di flusso:

0,03 gpm to 12 gpm*

0,11 l/mn to 45 l/mn*

Injection Range

Dosage:

Dosierung:

Dosificación:

Injeção:

Dosaggio:

0,025% to 20%

1:4000 to 1:5

Operating Pressure:

Pression:

Druck:

Presión operativa:

Pressão operativa:

Pressione operativa:

6 to 140 psi*

0,41 to 6,9 bar*

*Specifications vary by model.

*Les données techniques varient selon les modèles.

* Technische Daten sind je nach Modell unterschiedlich.

* Características técnicas varían según modelo.

* Características técnicas variam conforme o modelo.

* Le specifiche variano a seconda del modello.

Hydro
systems

A **DOVER** COMPANY

Quick Start Up
 Démarrage Rapide
 Schnell Antrieb

Puesta en marcha rápida
 Inicialização rápida
 Avvio rapido

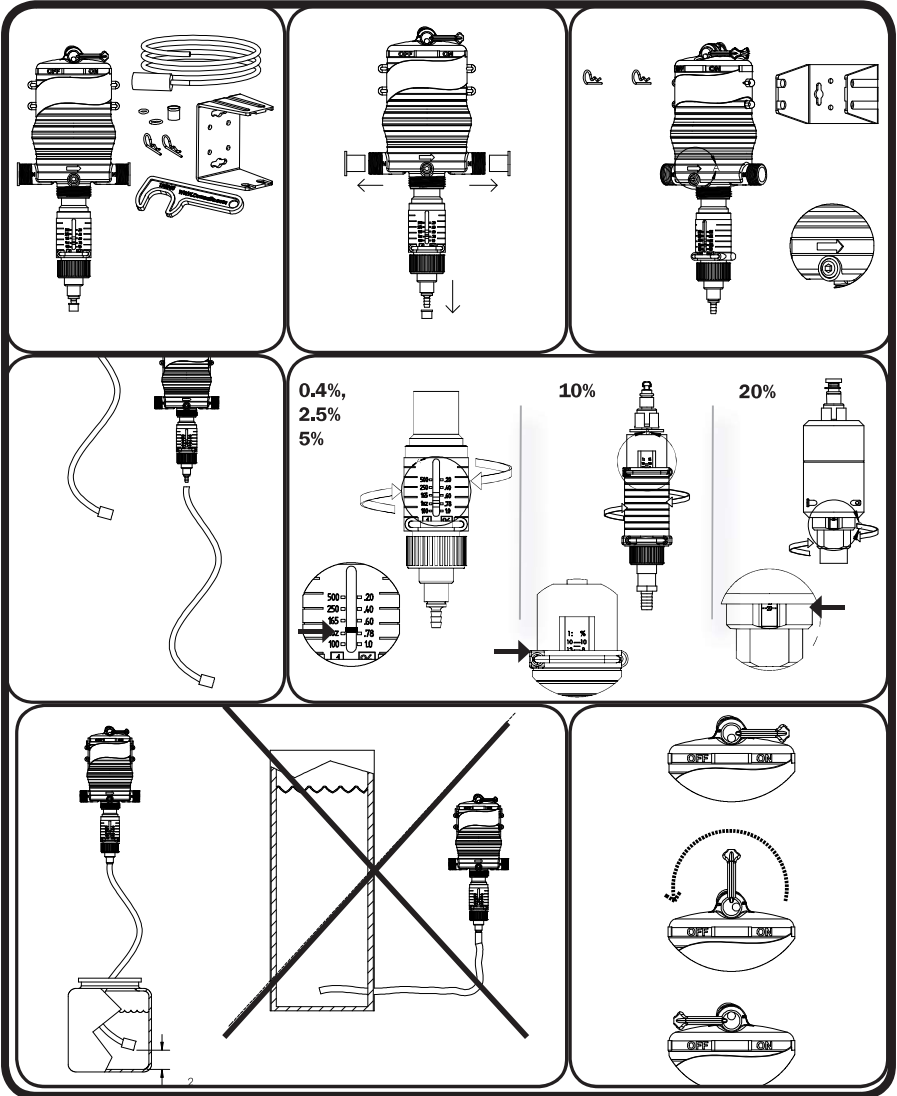

Part # 013815 Rev. J



English.....3-25

Français.....26-39

Deutsch.....40-53

Español.....54-67

Português.....68-81

Italiano.....82-95

Hydro Systems Company Offices:

North America & Global Headquarters:
 Hydro Systems Company
 3798 Round Bottom Road
 Cincinnati, OH 45244
 Phone: 513-271-8800
 Fax: 513-271-0160
 Toll Free: 800-543-7184

Europe, Middle East, Africa, & India
 Hydro Systems Europe
 Unit 3, The Sterling Centre,
 Eastern Road
 Bracknell, Berkshire
 RG12 2PW
 Europe
 Phone: +44 1344 488880
 Fax: +44 1344 488879

Asia Pacific:
 Hydro Systems Asia Pacific
 Unit A
 1 Kelham Place
 Glendenning, NSW 2761
 Australia
 Phone: 612-9625-8122
 Fax: 612-9625-8177

South America:
 Hydro Systems South America
 Rua Mogiana, 172,
 Chacarras Reunidas,
 Sao Jose Dos Campos,
 Brasil
 Phone: +55-12-3201-7707
 Fax: +55-12-3201-7739

Operating Principle

Accurate and Reliable

Installed directly in the fluid supply line, the injector operates without electricity, using fluid (water) pressure as the power source. The fluid drives the injector, which pulls the required percentage of concentrate directly from the chemical solution container. Inside the Hydro Systems patented mixing chamber, the concentrate is mixed with the fluid, and the fluid pressure forces the mixed solution downstream. The amount of concentrate will be directly proportional to the volume of fluid entering the injector, regardless of variations in flow or pressure.

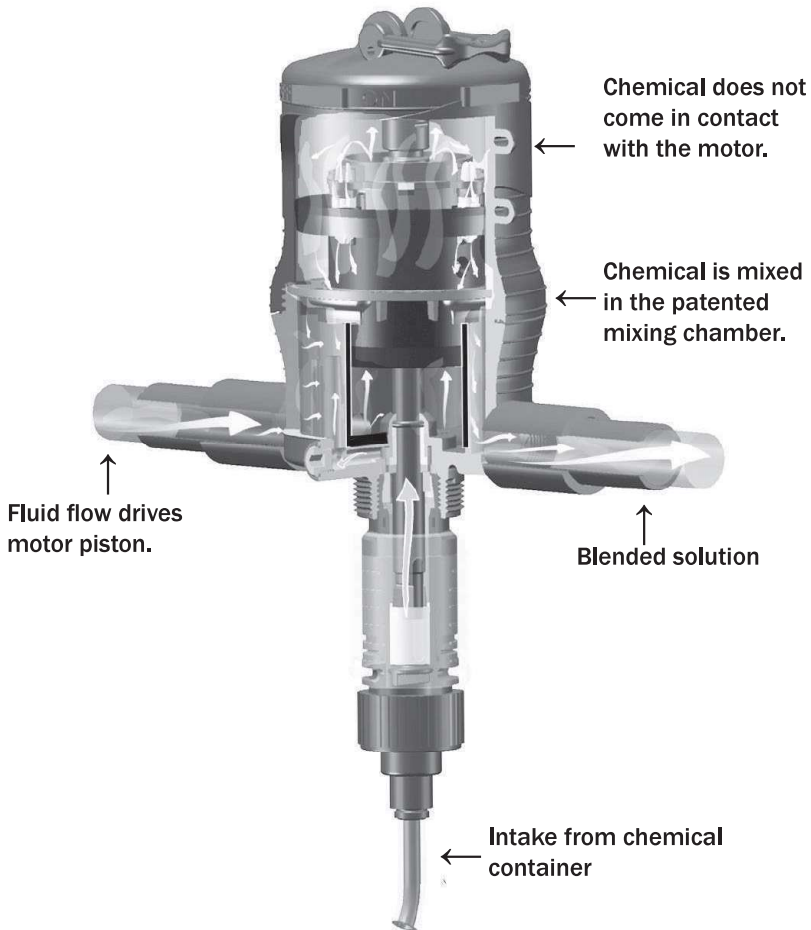

Contents

Operating Principle	4
Package Contents	6
Specifications	6
Safety Precautions	7
Warranty Compliance	7
General Tips	7
Operations	8
Installation and Start-up	9
Suggested Installation Diagram	9
Maintenance	10
Remote Injecting	10
Routine Maintenance Instructions 0.4%	11
Routine Maintenance Instructions 1%	12
Routine Maintenance Instructions 2.5% & 5%	13
Routine Maintenance Instructions 10%	14
Routine Maintenance Instructions 20%	15
Troubleshooting	16
Injector Repair Parts	17
Lower end injector & wear parts kits 0.4% PAA:	18
Lower end injector & wear parts kits 0.4%:	19
Lower end injector & wear parts kits 1%:	20
Lower end injector & wear parts kits 2.5%:	21
Lower end injector & wear parts kits 5%:	22
Lower end injector & wear parts kits 10%:	23
Lower end injector & wear parts kits 20%:	24
Warranty	25

Please read this manual carefully before putting the Hydro Systems injector into operation.

This booklet has the information you will need for the use and care of your new Hydro Systems injector. If you have any further questions about your injector, the warranty, routine maintenance or proper usage, please contact your nearest distributor or Hydro Systems customer service.

These models are designed to inject liquid concentrate or soluble powder that are recommended and approved for injection into fluid systems.

It is the responsibility of the operator to determine the correct dosage settings of the unit using the chemical manufacturers' recommendation for dispensing their product, and to assure that proper dosage is being maintained.

Maintenance and Warranty

Hydro Systems offers a three year limited warranty from the original date of purchase for manufacturing or materials defects only. With proper use and care, your injector should provide you long-term performance. Please review the complete warranty information on page 25.

For Your Records

The serial number of your Hydro Systems injector is located on the injector body. Please record this number in the space below and reference it when calling your distributor or Hydro Systems for information, parts and service.

Serial #.....

Date Purchased

This document does not form a contractual engagement on the part of Hydro Systems and is for information only. Hydro Systems reserves the right to alter product specifications or appearance without prior notice.

Package Contents

The injector is packaged with the following items:

- | | |
|------------------------------------|-------------------------|
| Hydro Systems Injector (not shown) | Mounting Bracket |
| Dosage Piston | Mounting Nuts and Bolts |
| O-ring | Filter |
| Manual (not shown) | Suction Tube |
| Lower Shaft Assembly | |

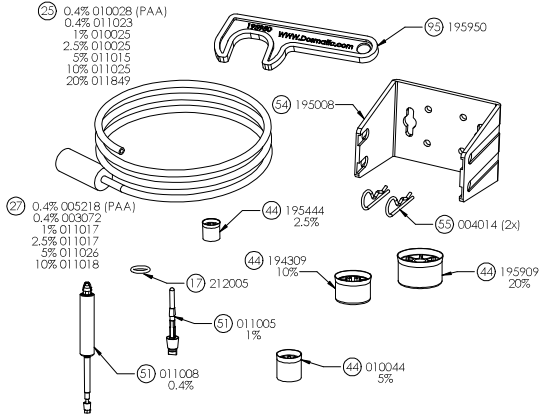

	Model	NPT	BSP
	0.4%	112608	112609
	0.4% Heavy Duty	112638	112639
	0.4% PAA	112608K	112609K
	1%	112600	112601
	1& Heavy Duty	112630	112631
	2.5%	112602	112603
	2.5% Heavy Duty	112632	112633
	5%	112604	112605
	5% Heavy Duty	112634	112635
	10%	112606	112607
	10% Heavy Duty	112636	112637
	20%	112620	112621
	20% Heavy Duty	112640	112641
	20% Remote Injection	112622	112623

Specifications



MiniDos 7 gpm (65 max. psi)

Model 20% 4% - 20% (1:25 - 1:5)
 Flow Rate: 0,07 - 7 gpm (0,26 - 27 l/mn)
 Operating Pressure: 6 - 65 psi (0,41 - 4,5 bar)
 Pipe Coupling: 3/4" NPT/BSP

MiniDos 10 gpm (65 max. psi)

Model 10% 2% - 10% (1:50 - 1:10)
 Flow Rate: 0,07 - 10 gpm (0,26 - 38 l/mn)
 Operating Pressure: 6 - 65 psi (0,41 - 4,5 bar)
 Pipe Coupling: 3/4" NPT/BSP

MiniDos 12 gpm (140 max. psi)

Model 0,4% 0,025% - 0,4% (1:4000 - 1:250)
 Model 1% 0,20% - 1% (1:500 - 1:100)
 Model 2,5% 0,50% - 2,5% (1:200 - 1:40)
 Model 5% 1% - 5% (1:100 - 1:20)
 Flow Rate: 0,03 - 12 gpm (0,11 - 46 l/mn)
 Operating Pressure: 6 - 140 psi (0,41 - 9,7 bar)
 Pipe Coupling: 3/4" NPT/BSP

Housing	Proprietary Engineered Composite Material
Dosing Accuracy	+/- 10% of ratio
Repeatability	+/- 3% of ratio
Pressure Loss	Available upon request
Maximum Temp.	100°F (38°C)
Minimum Temp.	34°F (1°C)
Maximum vertical suction of concentrate	13 Feet (3.6 Meter)
Maximum horizontal suction of concentrate	49 Feet (15 Meter)
Self-Priming	Yes
Seal Material Available: <small>*Contact your Hydro Systems representative for specific chemical information</small>	Aflas Viton EPDM Kalrez Teflon Coated
Maximum Viscosity	1,500 cP (Ex. Honey)
Recommended Accessories	140 mesh (104 micron) filter, check valve, pressure regulator, flow restrictor.

Safety Precautions Warranty Compliance



Warning, Please read precautions thoroughly before operation. Must meet all applicable local codes and regulations.

Remove Red Caps Prior to Installation

Your injector is 100% factory tested before delivery and may contain a small amount of water. The three red plastic caps are fitted after testing to ensure cleanliness of the injector.

Before Applying Aggressive Chemicals

Please consult your distributor, chemical manufacturer or contact Hydro Systems's customer service to confirm compatibility with your injector. Always wear proper safety protection as recommended by chemical supplier.

Label all Fluid Lines, Valves and Connections

If the solution that is being injected is not suitable for drinking, all fluid lines should be labeled:

Warning not for human consumption!

Monitor Outlet Flow

It is the user's responsibility to monitor the output of chemical injected.

A Filter is Recommended and Required

Install a filter of 140 mesh (104 micron) or finer depending on your fluid quality to prolong the working life of the injector and for the warranty to be valid. A filter is imperative since most fluid contains impurities or particles, especially if the fluid source comes from a well, pond or lake.

Avoid a Potentially Hazardous Chemical Accident

Select a safe location. Chemical container should be kept away from children and/or high usage areas and the location must also not be susceptible to freezing temperatures.

Avoid Solution Contamination

Use only clean FILTERED fluid. Do not allow contaminants to enter the solution container. They can be pumped into the fluid line and may cause the spread of disease. Dirt, debris and other contaminants in the solution container may cause excessive wear to the unit.

Fluid Temperature

Min: 34 °F (1 °C) Max: 100 °F (38 °C)

Maximum Fluid Pressure

0,4%, 1%, 2,5%, 5% - 140 psi (9,7 bar)

10% & 20% models have maximum operating pressure of 65 psi (4,5 bar).

Operating pressure and flow are reduced while using remote injection kit.

Install a pressure regulator and/or pressure relief valve to ensure operating pressure does not exceed the maximum specification.

Before Removing An Injector From The System

Release fluid pressure. While the system is in operation, turn off the incoming fluid valve. Leave the out going valve open this will relieve the pressure at the injector and all parts of the system after the injector. Injector is now safe to remove.

General Tips

Please read this instruction manual thoroughly. Following the procedures, will increase the life of your injector.

For A Long Service Life

Start with clean fluid by using an inline filter to reduce impurities. Keep the solution container covered and clean. Keep the suction tube filter 2" (5 cm) from the bottom of the container. Perform maintenance procedures as recommended (see Maintenance page 10).

Soluble Powder Use

Ensure the chemical is completely dissolved before starting the injector. If necessary, dissolve the chemical in hot water and allow to cool before using. Failure to thoroughly dissolve the chemical will cause premature wear to the dosage piston and the inner cylinder.

Keep From Extreme Temperature

Protect the injector from freezing temperatures or excessive heat.

Rinse Injector After Each Use

Additive allowed to remain in injector can dry out, foul or damage the lower end at the next start-up (see Maintenance page 10).

Injector Not in Use for an Extended Period

If the injector has not been stored properly deposits may have dried onto the motor (see Maintenance page 10). Before operation, soak entire unit into room temperature water approx. 72 °F (22 °C) for an eight hour period.

Operations

Clicking Sound is Normal

Fluid flowing through the injector will automatically cause the injector to "click" and inject a set amount of solution into the fluid line. The higher the flow rate the more frequent the "clicking". The injector is designed to inject solution proportionally (at the same set ratio) regardless of fluid flow.

Service Fluid Flow

Fluid flow and pressure must be within the established specifications (see Specification on page 6) for your model.

Change Feed (Injection) Rate

The feed rate on the injector is adjustable EVEN WHILE OPERATING AND UNDER PRESSURE. To change feed rate see Fig 1 (a, b or c) and Fig 2 (a, b or c) based on your injection rate. Do not remove #79 when injector is under pressure.

MiniDos 0.4%, 1%, 2.5% and 5%, see Fig 1a and 2a

Rotate Ratio Adjuster (#61) (Fig 1a) up or down using the Setting Indicator Mark (Fig 2a) to select the desired feed rate.

MiniDos 10%, see Fig 1b and 2b

1. Remove Interlock Pin (#65) (Fig 1b.).
2. Rotate Ratio Adjuster (#61) up or down to the desired setting. Use the top of the Ratio Adjuster Sleeve to line up with the desired feed rate setting (Fig 2b).
3. Re-insert Upper Interlock Pin (#65). Clip must be parallel with settings to be able to re-insert.

MiniDos 20%, see Fig 1c and 2c

1. Remove Ratio Locking Pin (#79) (Fig 1c.).
2. Rotate Outer Cylinder (#7) up or down to the desired setting. Use the top of the Outer Cylinder to line up with the desired feed rate setting (Fig 2c).

Bypass Operation

Injecting solution into the fluid line can be TEMPORARILY stopped with the On/Off feature (Fig. 3). Moving the On/Off Lever to the OFF position allows service fluid to pass through the injector without injecting chemical. No "clicking" will be heard.

With the On/Off lever set to the ON position the injector will operate as normal and "clicking" will be heard when fluid is flowing. It is recommended to use the three-valve bypass (see Fig. 5), for continued bypassing or servicing of the injector.

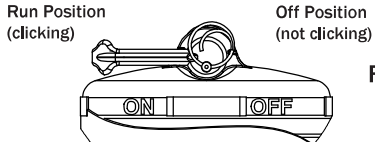

Fig. 3

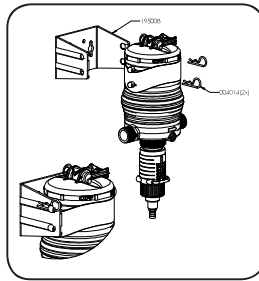

Fig. 4
Typical wall
mounting

**NOTE: Do not adjust feed rate below lowest setting line.
Measure outlet fluid to assure desired feed rate is being delivered.**

MiniDos 0.4%, 1%, 2.5% and 5%

Fig. 1a

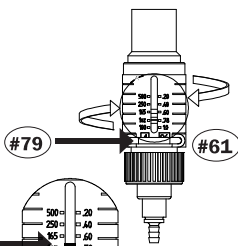

Fig. 2a



MiniDos 10%

Fig. 1b

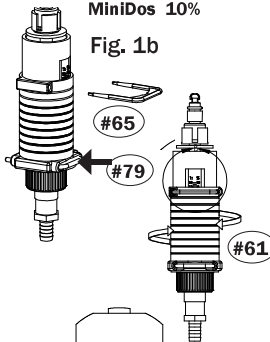
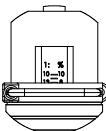

Fig. 2b



MiniDos 20%

Fig. 1c

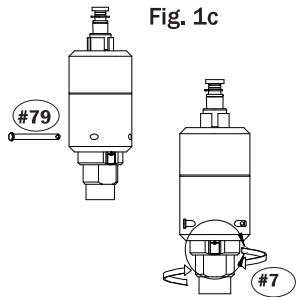
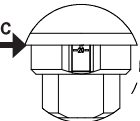

Fig. 2c



Installation and Start-up

Refer to Fig. 4 and Fig. 5

Fluid Filter (Required)

Install a filter of 140 mesh (104 micron) or finer depending on your fluid quality to prolong the working life of the injector and for the warranty to be valid. Hydro Systems recommends a Twist II Clean® filter that can be ordered with your injector.

Mounting Injector

Securely fasten your injector to a solid object such as a wall or in a cold fluid line. Note arrow on injector indicates fluid flow.

Backflow Preventor (Recommended)

Install one that meets local code requirements.

Pressure Safety Release Device (Recommended)

Prevents pressure from exceeding specifications of the unit.

Bypass Valve Set-up (Recommended)

Allows the injector to be taken off-line for maintenance or storage when not in use.

Fluid-Hammer Arrester (Recommended)

Prevents fluid-hammer damage to the injector when operating quick closing solenoid, pneumatic or hand-operated ball valves on the fluid system.

Anti-Siphon Valve (Optional)

To prevent solution from being siphoned out (from the solution container) into the feed lines when the upstream valve is shut off. The anti-siphon valve must be installed on the downstream outlet.

Additional Siphoning Prevention

Place solution container on a level below the injector suction tube fitting. Using the inlet side as a shut-off valve could cause full strength solution to siphon into the feed line.

Solution Container

Use any size container. A lid or cover is recommended. To connect your solution container, gently push the end of the suction tube onto the bottom of the suction tube fitting assembly.

Place the filter into the solution container at least 2" (5cm) from the bottom and fill with at least 2" (5cm) of chemical solution.

Never Use Petroleum Based Lubricants

The injector is shipped with a thin coat of silicone around the seals for ease-of-assembly. Petroleum based lubricants such as Vaseline®, baby oil, WD40®, or motor oil on the O-rings or any part of the injector should never be used as this can cause particles to adhere and clog or damage the injector.



Check System for Leaks and Start-Up Procedures

Open the bypass valve (A), close inlet valve (B) and outlet valve (C) to prevent fluid flow into the injector, **SLOWLY** turn on the main fluid line. Run fluid flows between 5 -12 gpm (11-45 l/m) through the plumbing system. Turn on all of the valves located downstream from your injector to release trapped air. **SLOWLY** turn on the inlet valve (B). Open the outlet valve (C) and close valve (A). As fluid travels through the injector, you will hear a "clicking" sound. Check for leaks and correct if necessary.

Suggested Installation Diagram

Fig. 5

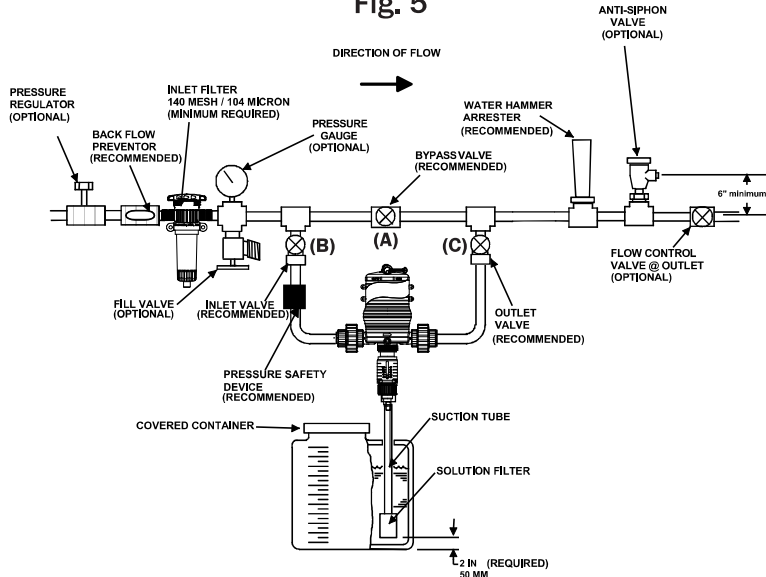

Remote Injecting

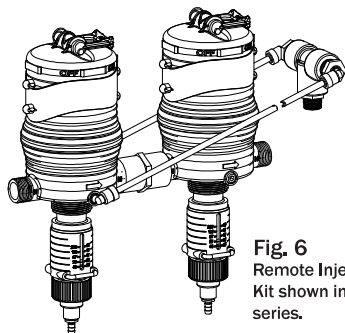

Fig. 6
Remote Injector
Kit shown in a
series.

Remote Injector Kit (not included)

Is recommended for the following:

Kit Part Numbers
011762

Injectors In a Series:

When injecting multiple chemical injections, using two or more injectors. Each injector adds chemical to the fluid(water) system, while bypassing the next injector and eliminating the potential damage to that injector (see Fig. 6). To prevent mineral buildup within the body of the unit. Use when injecting chemicals that cause minerals to precipitate from fluid.

NOTE: when mixing more than one chemical, always refer to your chemical manufacturer information guide for proper application. Contact your local distributor or Hydro Systems customer service for information or to order.

Maintenance

Reference numbers refer to Page 17 - 24

RINSE INJECTOR AFTER EACH USE

Additive allowed to remain in injector can dry, foul or damage the lower end at the next start-up. Place suction tube into a 1 qt. (0.95 liters) or more container of fresh filtered water. Flow fresh water through the injector by operating until container is empty. This procedure is not needed for continuous operation.

CLEAN SOLUTION CONTAINER

Keep covered to prevent dirt, flies, feathers and other flying debris from entering the container. Rinse container thoroughly and often. Do not mix chemicals together that might react and cause a precipitate. Use **FILTERED** fluid when filling container.

CLEAN SUCTION TUBE FILTER SCREEN

Inspect each time new solution is added. Clean filter screen (#27) and suction tube (#25) as necessary by rinsing in fresh water. Replace if necessary. Keep filter screen off bottom of solution container to prevent dirt and precipitate from clogging filter.

CLEAN INLET FILTER

Clean or replace inlet filter as required to increase the life of the unit as well as reduce pressure loss.

BYPASS INJECTOR

When not in use place the injector in bypass mode by using the three valve bypass (preferred) or turn the On/Off lever on the top of the injector to the off position.

STORAGE

For extended storage, rinse injector (see "Rinse Injector After Each Use") and place underwater in a container. Apply monthly, <0.1 oz. (29 ml) of chlorine bleach to avoid algae growth.

KEEP FROM FREEZING.

MiniDos (0,4%)
& (0,4) PAA
Refer to pages
18 & 19

MiniDos (1%)
Refer to page 20

MiniDos (2,5%)
& (5%) Refer to
pages 21 & 22

MiniDos (10%)
Refer to page 23

MiniDos (20%)
Refer to page 24

Perform these maintenance

procedures to extend the life of your unit.

Every 3 - 6 Months	Every 6 - 12 months	Replace as necessary
1. Clean seal area (#13). 2. Check #17 O-ring, #51 Shaft Assembly, clean and/or replace as necessary.	1. Replace #17 O-ring and #51 Shaft Assembly. 2. Clean and/or replace #13 Check Poppet, #11 Suction Tube Fitting.	1. #37 Cylinder 2. #17 O-ring 3. #51 Shaft

Every 3 - 6 Months	Every 6 - 12 months	Replace as necessary
1. Clean seal areas (# 17, 14 & 13). 2. Check #17 O-ring, # 68 Cylinder, clean and/or replace as necessary.	1. Replace #17 O-ring and #44 Dosage Piston. 2. Clean and/or replace #13 Check Poppet, #11 Suction Tube Fitting.	1. #68 Cylinder 2. #14, #17 O-ring 3. #51 Shaft 4. #44 Dosage Piston

Every 3 - 6 Months	Every 6 - 12 months	Replace as necessary
1. Clean seal areas (# 17, 14 & 13). 2. Check #17 O-ring, #37 Cylinder, clean and/or replace as necessary.	1. Replace #17 O-ring and #44 Dosage Piston. 2. Clean and/or replace #13 Check Poppet, #11 Suction Tube Fitting.	1. #37 Cylinder 2. #14, #17 O-ring 3. #52 Shaft 4. #44 Dosage Piston.

Every 3 - 6 Months	Every 6 - 12 months	Replace as necessary
1. Clean seal areas (# 17, 14 & 13). 2. Check #17 O-ring, #37 Cylinder, clean and/or replace as necessary.	1. Replace #17 O-ring and #44 Dosage Piston. 2. Clean and/or replace #13 Check Poppet, #11 Suction Tube Fitting.	1. #37 Cylinder 2. #14, #17 O-ring 3. #52 Shaft 4. #44 Dosage Piston

Every 3 - 6 Months	Every 6 - 12 months	Replace as necessary
1. Clean seal areas (# 17, 14). 2. Check #17 O-ring, #7 Cylinder, clean and/or replace as necessary.	1. Replace #17 O-ring and #44 Dosage Piston. 2. Clean and/or replace #60.	1. #7 Cylinder 2. #14, #17 O-ring 3. #44 Dosage Piston

Routine Maintenance Instructions 0.4%

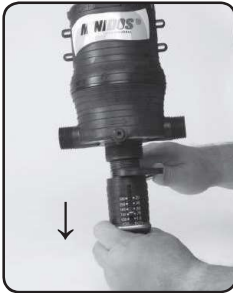

Step 1.
Unscrew #7 OUTER CYLINDER
from body.

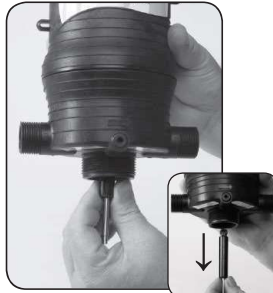

Step 2.
1/4 turn to remove #51 SHAFT
ASSEMBLY



Step 3.
Remove #16 Gasket.



Step 4.
Remove #82 SHAFT SEAL SPACER.



Step 5.
Remove #17 O-ring.



Step 6.
Replace #17 O-ring.



Step 7.
Replace #82 SHAFT SEAL
SPACER and #16 Gasket.



Step 8.
Replace #51 SHAFT ASSEMBLY.



Step 9.
Screw #7 OUTER CYLINDER
onto body.

Routine Maintenance Instructions 1%

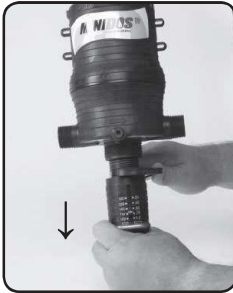

Step 1.
Unscrew #7 OUTER CYLINDER from body.



Step 2.
1/4 turn to unlock and remove #51 LOWER SHAFT and replace.

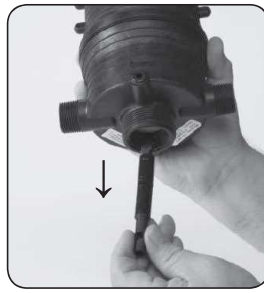

Step 3.
Remove #52 UPPER SHAFT.

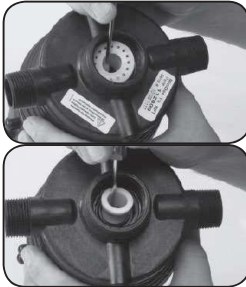

Step 4.
Remove and clean #16 GASKET and #82 SEAL SPACER.



Step 5.
Remove #17 O-ring and replace.



Step 6.
After replacing #82 SEAL SPACER and #18 GASKET, replace #52 UPPER SHAFT, Turn 1/4 turn to lock in place.



Step 7.
Re-install #82 SEAL SPACER and #16 GASKET.

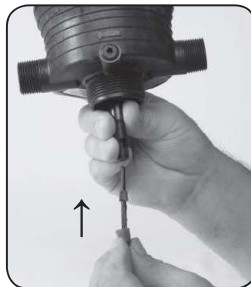

Step 8.
Reinstall lower shaft with new dosage piston and turn 1/4 turn to lock.

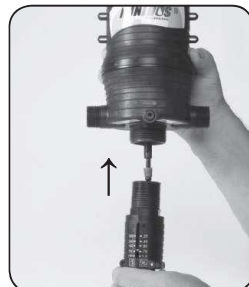

Step 9.
Screw #7 OUTER CYLINDER onto body.

Routine Maintenance Instructions 2.5% & 5%

English

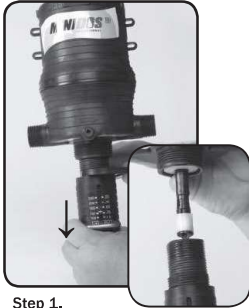

Step 1.
Unscrew #7 OUTER CYLINDER
from body.

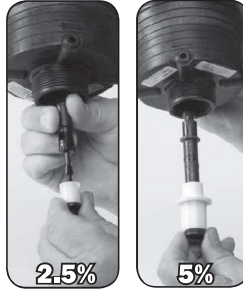

Step 2.
Rotate #51 or #52 SHAFT 90°
and remove.

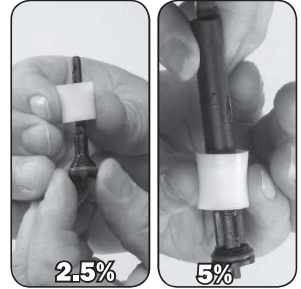

Step 3.
Replace #44 DOSAGE PISTON thin
lips up. Clean & inspect #14 O-ring
replace if necessary.



Step 4.
Remove & Clean seal areas #16
& #82.

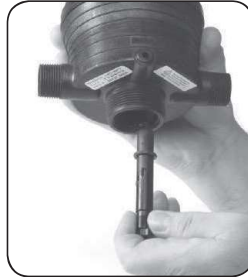

Step 5.
Replace #17 O-ring.



Step 6.
Re-install #52 UPPER SHAFT
and #17 O-ring.



Step 7.
Re-install #16 GASKET and #82
SEAL SPACER



Step 8.
Reinstall lower shaft with new
dosage piston by turning 90°
to lock in place.



Step 9.
Screw #7 OUTER CYLINDER
onto body.

Routine Maintenance Instructions 10%



Step 1.
Unscrew #7 OUTER CYLINDER
from body.



Step 2.
1/4 turn and remove #52 SHAFT,
#16 GASKET and #15 RETAINER.



Step 3.
Remove #83 SHAFT SEAL
SPACER.



Step 4.
Remove #17 O-ring and replace.



Step 5.
Replace #83 SHAFT SEAL
SPACER.



Step 6.
Squeeze ears on shaft and
remove #44 DOSAGE PISTON.



Step 7.
Replace #44 DOSAGE PISTON
thin lips up (towards the top of
the shaft).

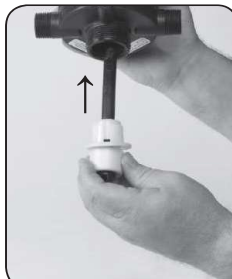

Step 8.
Re-install #52 SHAFT with #16
GASKET, #15 RETAINER.

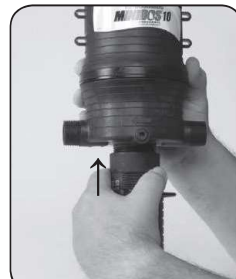

Step 9.
Screw #7 OUTER CYLINDER
onto body.

Routine Maintenance Instructions 20%

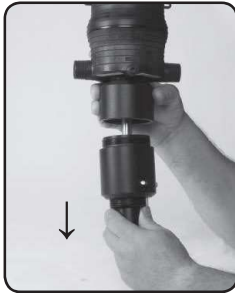

Step 1.
Unscrew #61 OUTER CYLINDER from body.



Step 2.
Unscrew to unlock and remove #93 CAPSCREW.

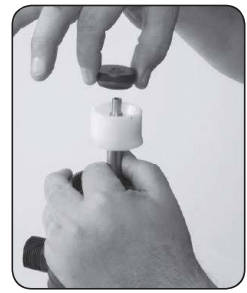

Step 3.
Remove #73 DOSAGE PISTON GUIDE, clean and inspect #14 O-ring.

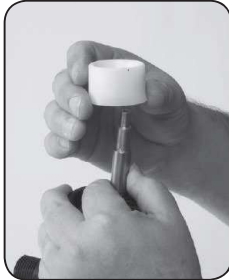

Step 4.
Remove #44 DOSAGE PISTON.



Step 5.
Unscrew and remove #72 ADAPTER as well as #68 O-ring, #15 SEAL RETAINER, Clean and replace if damaged or worn.



Step 6.
Remove and replace #17 O-ring, Re-install #83 SHAFT SEAL SPACER and #15 SEAL RETAINER.



Step 7.
Reset #68 O-ring and screw #72 ADAPTER onto body.

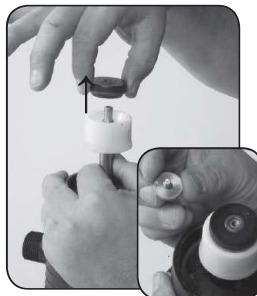

Step 8.
Replace #73 DOSAGE PISTON GUIDE and #44 DOSAGE PISTON.



Step 9.
Screw #61 OUTER CYLINDER onto body.

Troubleshooting

New Install - Always Pressure Up Slowly (Follow start up on page 9)

Problem	Cause	Solution
No Clicking Sound	Fluid not flowing through unit	Are the red plugs at the inlet, outlet and suction tube fitting openings removed? Is the unit installed backward? The arrow on the unit must point in the direction of the fluid flow. Has the new injector been stored for an extended period. If so, submerge the injector in room temperature water for 24 hours so that the working parts can reabsorb fluid and swell back to the proper size. If still not clicking, do not open the upper body. Call Hydro Systems Customer Service.
	Fluid flowing through unit	Fluid rate is below or exceeds rated service flow of injector. (See Specifications page 6). If below increase flow rate, if above, reduce flow rate. Operating pressure exceeds maximum limit. Install a pressure reducer valve. (See Specifications for maximum flow rate page 6). On/Off Lever in off position. Place the On/Off lever switch to the ON position. By-Pass Valve not closed. Check and set valve to the OFF position.

Injector in Operation or After Scheduled Maintenance

Problem	Cause	Solution
No Clicking Sound	Main Piston Assembly #9 worn	Replace # 9 Main Piston Assembly. Clean fluid filter.
	Cover #1 or main body #40 worn or scored	Replace and install or clean fluid filter.
	On/Off Lever in off position	Place the On/Off Lever switch to the ON position.
	By-Pass Valve not closed	Set Valve to the closed position.
	Dirty or plugged inlet filter	Ensure mesh size is correct for proper filtration. Clean filter.
	#17 Worn or not seated properly	Re-seat #17 or replace.

Problem	Cause	Solution
Clicking Sound No Suction Of Solution	Suction tube #25 (#60 - 20%) or suction tube fitting #11 cracked, loose, leaking or clogged suction tube filter.	Check for proper fit, replace and/or clean as necessary.
	Dosage piston #44 worn or installed incorrectly, inner cylinder #37 (#68 - 1% & #7 - 20%) worn	Replace. Ensure during maintenance replacement that #44 dosage piston was installed correctly flared-end up.
	O-ring retainer #82 (#15 - 10% & 20%) installed incorrectly	Install correctly.
	O-ring seat #14 or dosage piston #44 damaged or worn	Replace, on 0.4% models replace #51 Shaft Assembly.
	Check valve #13 (#60 - 20%) leaking.	Clean & replace as necessary.

Problem	Cause	Solution
Clicking Sound. Under Injecting	#44 Dosage Piston worn	Replace, on 0.4% models replace #51 Shaft Assembly.
	#37 (#7 - 20%) Inner Cylinder worn	Replace.
	Unit operates at high-flow and not at low flow	Replace #17 O-ring.
	Main Piston Assembly #9 worn	Replace # 9 Main Piston Assembly. Clean fluid filter.
	Cover #1 or main body #40 worn or scored	Replace and install or clean fluid filter.

Problem	Cause	Solution
Fluid Re-filling Solution Tank	Check valve #13 leaking	Check seat area on suction tube fitting #11. Check valve and seal must fit loose in the suction tube fitting. Clean seal and inside fitting for debris.
	Washer seal on #13 is swollen or chemical attack	Replace with new check valve assembly.
	Hose Kit #60 (20%) leaking	Replace

Injector Repair Parts

Reference #	Part #	Description
1	190100	Upper Body
9	011666 011662UP 20%	Motor Piston
20	212009	O-ring
21	195700	Bypass Shaft
34	193641	Cotter Ring
40	011012 011013 011010 011011 011010REM 011011REM	NPT Lower Body BSP Lower Body 20% NPT 20% BSP 20% NPT Remote Inject 20% BSP Remote Inject
85	195912 195914 (Heavy Duty Pin)	Upper Shaft Pin
86	195720	Mixing Chamber Gasket
87	195910	On/Off Handle

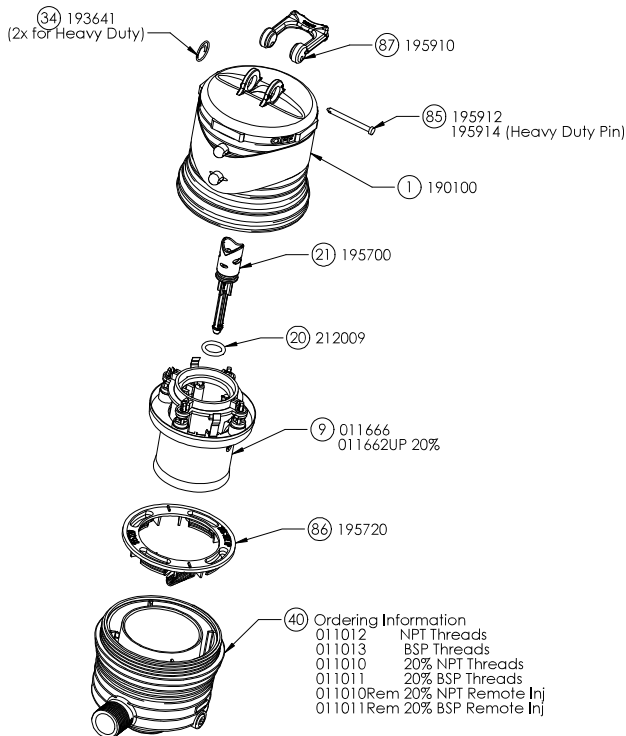

Lower end injector & wear parts kits 0.4% PAA:

Kit A - Wear Parts Kit (dosage piston/ lower shaft assy. and O-ring)	011109K	17, 51
Kit C - Wear Parts Kit (Kit A, inner cylinder and O-ring)	011110K	12, 17, 37, 51
Kit D - Suction Tube Fitting Assy (poppet, O-ring, fitting, spring)	011111K	13, 27
Kit E - Wear Parts Kit (Kits C & D, upper shaft)	011112K	12, 16, 17, 37, 51
Kit G - Lower End Kit, complete (Kit E, outer cylinder, ratio adjuster, O-ring, retainer clip, pin, retainer, filter, solution tube)	011113K	7, 12, 13, 16, 17, 25, 27, 37, 51, 60, 61, 79, 82
Kit H - Motor Piston Assy (upper end kit)	011662S	9, 20, 21
Kit I - Remote Injection Kit	011762 (Viton) 011764 (EPDM)	Not Shown
Kit M - Mounting Bracket Kit (mounting bracket, 4 hex caps & nuts)	011732	54, 55

Manual Reference	Part #	Description of Part
7	190031	Minidos Outer Cylinder
12	212120X	O-ring
13	003043K	Check Poppet W/Washer
16	195709	Gasket
17	212005K	O-ring
25	010028	Suction Tube 1/8" X 3'
27	005218	1/4"OD x 1/8"ID Compression x 3/8" NPT Male
37	195976	Minidos 0.4% Inner Cylinder
51	011008K	Minidos 0.4% Shaft Assembly
60	212517W	O-ring
61	195874	Minidos 0.4% Ratio Adjuster
79	195224	Interlock Pin
82	195740	Shaft Seal Spacer

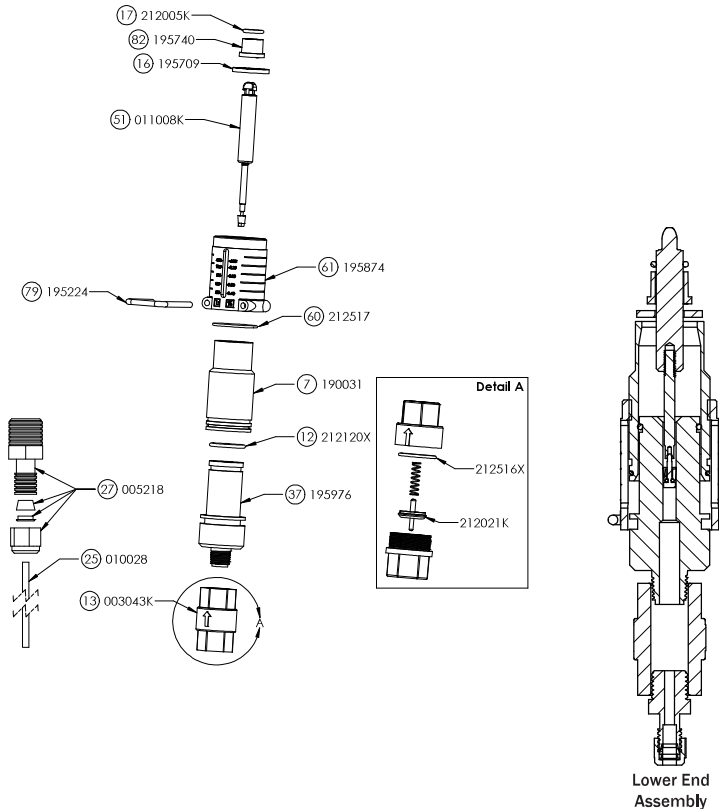

Lower end injector & wear parts kits 0.4%:

Kit A - Wear Parts Kit (dosage piston/ lower shaft assy, and O-ring)	011109V	17, 51
Kit C - Wear Parts Kit (Kit A, inner cylinder and O-ring)	011110V	12, 17, 37, 51
Kit D - Suction Tube Fitting Assy (poppet, O-ring, fitting, spring)	011111	10, 11, 13, 91
Kit E - Wear Parts Kit (Kits C & D, upper shaft)	011112V	10, 11, 12, 13, 16, 17, 37, 51,
Kit G - Lower End Kit, complete (Kit E, ratio adjuster, O-rings, pin, filter, solution tube)	011113V	7, 10, 11, 12, 13, 16, 17, 25, 27, 37, 51, 60, 61, 82, 91, 92
Kit H - Motor Piston Assy (upper end kit)	011662S	9, 20, 21
Kit I - Remote Injection Kit	011762 (Viton) 011764 (EPDM)	Not Shown
Kit M - Mounting Bracket Kit (mounting bracket, 4 hex caps & nuts)	011732	54, 55

Ref. #	Part #	Description of Part
7	190031	Minidos Outer Cylinder
10	195877	Minidos 0.4% Spring
11	190202	Suction Tube Fitting, 1/8"
12	212120	O-ring
13	011453A	Check Poppet W/Washer
16	195709	Gasket
17	212005	O-ring
25	011023	Suction Tube 1/8" X 3'
27	003072	Filter For Suction Tube 1/8"
37	195876	Minidos 0.4% Inner Cylinder
51	011008	Minidos 0.4% Shaft Assy
60	212517W	O-ring
61	195874	Minidos 0.4% Ratio Adjuster
79	195224	Interlock Pin
82	195740	Shaft Seal Spacer
91	193054	Seal, Check Valve
92	193854	Hose Nut 1/8"

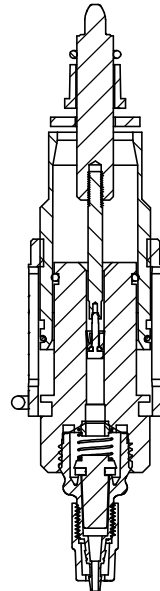
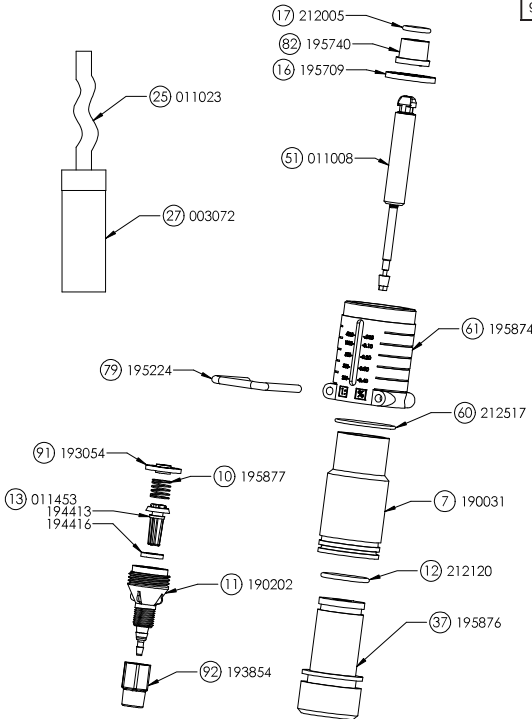

Lower End Assembly

Lower end injector & wear parts kits 1%:

Kit A – Wear Parts Kit (dosage piston, O-ring)	011071V	17, 51
Kit C – Wear Parts Kit (Kit A, inner cylinder, O-ring)	011072V	17, 51, 63, 68
Kit D – Suction Tube Fitting Assy (poppet, O-ring, spring, fitting)	011046V	10, 11, 12, 13, 80
Kit E – Wear Parts Kit (Kits C & D, upper shaft)	011073V	10, 11, 12, 13, 16, 17, 51, 52, 63, 68, 80
Kit G – Lower End Cylinder Kit (Kit E, outer cylinder, ratio adjuster, O-rings, pin, filter, solution tube)	011068V	7, 10, 11, 12, 13, 16, 17, 25, 26, 27, 37, 51, 52, 60, 61, 63, 68, 71, 79, 80, 82
Kit H – Motor Piston Assy	011662S	9, 20, 21
Kit I - Remote Injection Kit	011762 (Viton) 011764 (EPDM)	Not Shown
Kit M – Mounting Bracket Kit (mounting bracket, 2 pins)	011732	54, 55

Manual Reference	Part #	Description of Part
7	190011	Cylinder, Outer
10	194418H	Spring
11	194417	Suction Tube Fitting
12	212120	O-ring
		*Must specify material
13	011453A	Check Poppet W/Washer
16	195709	Gasket
17	212005	O-ring
		*Must specify material
25	010025	Suction Tube, ¼" X 5'
26	195761	Anti Lock Gasket
27	011017	Filter For Suction Tube, ¼" Id
37	195405	Inner Cylinder
51	011005	Lower Shaft Assembly
52	190030	Shaft, Upper
60	212517W	O-ring
61	195426	Ratio Adjuster
63	212516	O-ring, Inner Cylinder
		*Must specify material
68	190750	Inner Cylinder For #37
71	194414	Nut, Suction Tube Fitting
79	195224	Interlock Pin
80	194415	Twistlock
82	195740	Shaft Seal Spacer

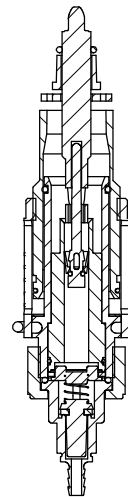
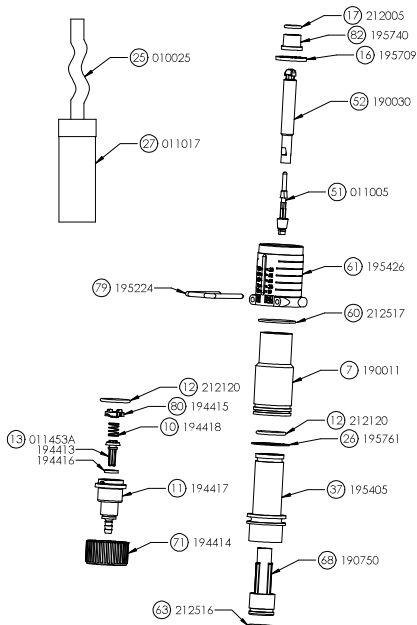

Lower End Assembly

Lower end injector & wear parts kits 2.5%:

English

Kit A – Wear Parts Kit (dosage piston, O-ring)	011055V	14, 17, 44
Kit B – Wear Parts Kit (Kit A, shaft)	011044V	14, 17, 44, 51
Kit C – Wear Parts Kit (Kit A, inner cylinder, O-ring)	011045V	12, 14, 17, 37, 44
Kit D – Suction Tube Fitting Assy (poppet, O-ring, spring, fitting)	011057V	10, 11, 12, 13, 80
Kit E – Wear Parts Kit (Kits C & D, upper & lower shaft, gasket)	011089V	10, 11, 12, 13, 14, 16, 17, 37, 44, 51, 52, 80
Kit G – Lower End Complete Kit (Kit E, outer cylinder, ratio adjuster, pin, filter, solution tube)	011047V	7, 10, 11, 12, 13, 14, 16, 17, 25, 26, 27, 37, 44, 51, 52, 60, 61, 71, 79, 80, 82
Kit H – Motor Piston Assy	011662S	9, 20, 21
Kit I - Remote Injection Kit	011762 (Viton) 011764 (EPDM)	Not Shown
Kit M – Mounting Bracket Kit (mounting bracket, 2 pins)	011732	54, 55

Ref. #	Part #	Description of Part
7	190011	Cylinder, Outer
10	194418H	Spring
11	194417	Suction Tube Fitting
12	212120 *Must specify material	O-ring
13	011453A	Check Poppet W/Washer
14	212501 *Must specify material	O-ring
16	195709	Gasket
17	212005 *Must specify material	O-ring
25	010025	Suction Tube, ¼" X 5'
26	195760	Anti Lock Gasket
27	011017	Filter For Suction Tube, ¼" Id
37	195404	Inner Cylinder
44	195444P	Dosage Piston
51	195408	Shaft, Lower
52	195727	Shaft, Upper
60	212517W	O-ring
61	195430	Ratio Adjuster
71	194414	Nut, Suction Tube Fitting
79	195224	Interlock Pin
80	194415	Twistlock
82	195740	Shaft Seal Spacer

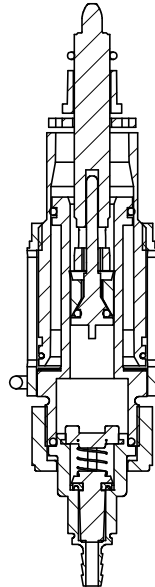
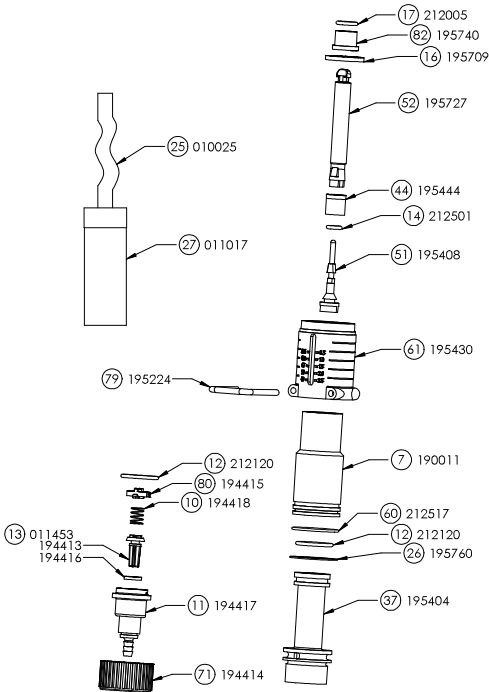

Lower End Assembly

Lower end injector & wear parts kits 5%:

Kit A – Wear Parts Kit (dosage piston, O-ring)	011076V	14, 17, 44
Kit B - Wear Parts Kit (Kit A, shaft)	011077V	14, 17, 44, 52
Kit C – Wear Parts Kit (Kit A, inner cylinder, O-ring)	011074V	12, 14, 17, 37, 44
Kit D – Suction Tube Fitting Assy (poppet, washer, O-ring, spring, fitting)	011079V	10, 11, 12, 13, 80
Kit E – Wear Parts Kit (Kits C & D, inner cylinder, 2nd inner cylinder, shaft, pin, gasket)	011080V	10, 11, 12, 14, 13, 16, 17, 37, 44, 52, 80
Kit G – Lower End Complete Kit (Kit E, outer cylinder, ratio adjuster, O-rings, pin, filter, solution tube)	011081V	7, 10, 11, 12, 13, 14, 16, 17, 25, 26, 27, 37, 44, 52, 60, 61, 71, 79, 80, 82
Kit H – Motor Piston Assy (upper end kit)	011662S	9, 20, 21
Kit I - Remote Injection Kit	011762 (Viton) 011764 (EPDM)	Not Shown
Kit M – Mounting Bracket Kit (mounting bracket, 2 pins)	011732	54, 55

Ref. #	Part #	Description of Part
7	190031	Cylinder, Outer
10	194418H	Spring
11	194412	Fitting, Suction Tube, 3/8"
12	212120	O-ring
		*Must specify material
13	011453A	Check Poppet W/Washer
14	212005	O-ring
		*Must specify material
16	195709	Gasket
17	212005	O-ring
		*Must specify material
25	011015	Suction Tube, 3/8" X 5'
26	195761	Anti Lock Gasket
27	011026	Filter For Suction Tube, 3/8" Id
37	195405	Inner Cylinder
44	010044P	Dosage Piston
52	195726	Shaft
60	212517W	O-ring
61	195428	Ratio Adjuster
71	194414	Nut, Suction Tube Fitting
79	195224	Interlock Pin
80	194415	Twistlock
82	195740	Shaft Seal Spacer

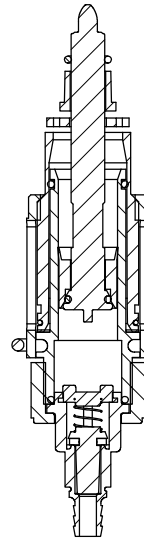
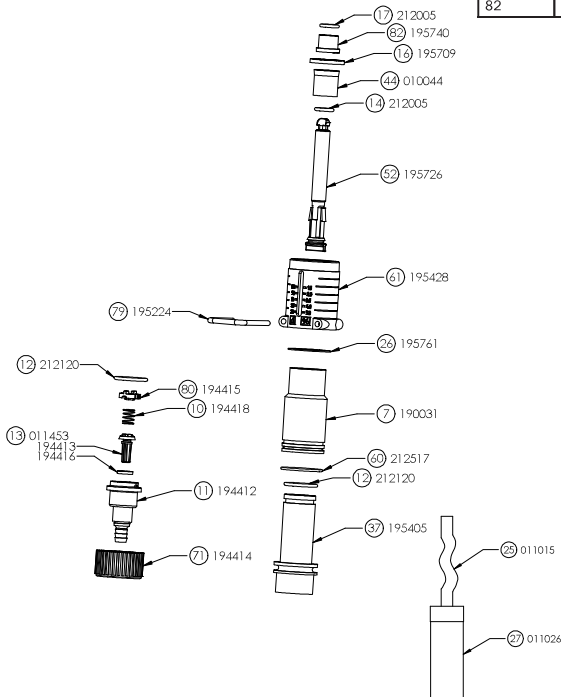

Lower End Assembly

Lower end injector & wear parts kits 10%:

Kit A – Wear Parts Kit (dosage piston, O-ring)	011082V	14, 17, 44
Kit B – Wear Parts Kit (Kit A, shaft)	011083V	14, 17, 44, 52
Kit C – Wear Parts Kit (Kit A, inner cylinder, O-ring)	011084V	14, 17, 37, 44, 64
Kit D – Suction Tube Fitting Assy (poppet, O-ring, spring, fitting)	011085V	10, 11, 12, 13, 80
Kit E – Wear Parts Kit (Kits C & D, inner cylinder, shaft, gasket)	011087V	10, 11, 12, 13, 14, 16, 17, 37, 44, 52, 64, 80
Kit G – Lower End Cylinder Kit (Kit E, outer cylinder, ratio adjuster, O-rings, retainer clip, retainer, pin, filter, solution tube)	011088V	7, 10, 11, 12, 13, 14, 15, 16, 17, 25, 27, 37, 44, 52, 61, 64, 65, 66, 71, 79, 80, 83
Kit H – Motor Piston Assy	011662S	9, 20, 21
Kit I - Remote Injection Kit	011762 (Viton) 011764 (EPDM)	Not Shown
Kit M – Mounting Bracket Kit (mounting bracket, 2 pins)	011732	54, 55

Manual Reference	Part #	Description of Part
7	195790	Cylinder, Outer
10	194418H	Spring
11	194420	Suction Tube Fitting
12	212120 *Must specify material	O-ring
13	011453A	Check Poppet W/Washer
14	212005 *Must specify material	O-ring
15	194004	Seal Retainer, O-ring
16	010016S	Gasket
17	212005 *Must specify material	O-ring
25	011025	Suction Tube, 1/2" X 5'
27	011018	Filter For Suction Tube, 1/2" Id
37	194405P	Inner Cylinder
44	194309	Dosage Piston
52	195729	Shaft
61	194406P	Ratio Adjustment Sleeve
64	212017 *Must specify material	O-ring, Inner Cylinder, Lower End
65	194310D	Interlock Pin
66	212025 *Must specify material	O-ring, Outer Cylinder, Lower End
71	194414	Nut, Suction Tube Fitting
79	194410SS	Retainer Clip Bottom
80	194415	Twistlock
83	190741	Shaft Seal Spacer

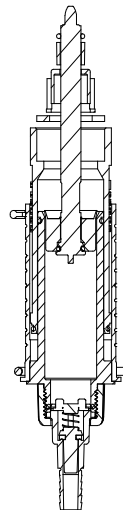
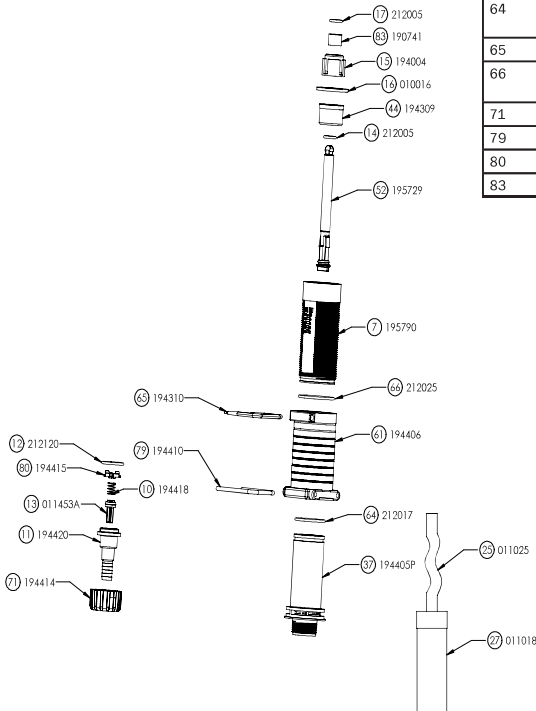

Lower End Assembly

Lower end injector & wear parts kits 20%:

Manual Reference	Part #	Description of Part
7	011913P	Inner Cylinder
14	212006 *Must specify material	O-ring
15	194004	Seal Retainer O-ring (Retainer Quad Ring)
17	212005 *Must specify material	O-ring
44	195909	Dosage Piston
51	011904	Shaft Assy
53	194344	Klipring
60	011849M *Must specify material	Hose Kit
61	195851	Outer Cylinder
66	212228 *Must specify material	O-ring
68	212002 *Must specify material	O-ring
72	195850	Adapter
72	190850	Remote Adapter
73	195855	Dosage Piston Guide
79	195911	Ratio Locking Pin
83	190741	Shaft Seal Spacer
91	212518 *Must specify material	O-ring
92	195861	Shaft Cap
93	193003	Capscrew 10-32 X 1/2" Ss Hex Head
94	212004 *Must specify material	O-ring

Kit A – Wear Parts Kit (dosage piston, O-ring)	011105V	14, 17, 44,
Kit B - Hose Kit	011849M	60
Kit C – Wear Parts Kit (Kit A, O-rings)	011106V	7, 14, 17, 44, 66, 68, 91, 94
Kit H – Motor Piston Assy (upper end kit)	011662UPS	9, 20, 21
Kit I - Remote Injection Kit (pg. 24)	012706	30, 31, 35, 36, 72
Kit M – Mounting Bracket Kit (mounting bracket, 2 pins)	011732	54, 55

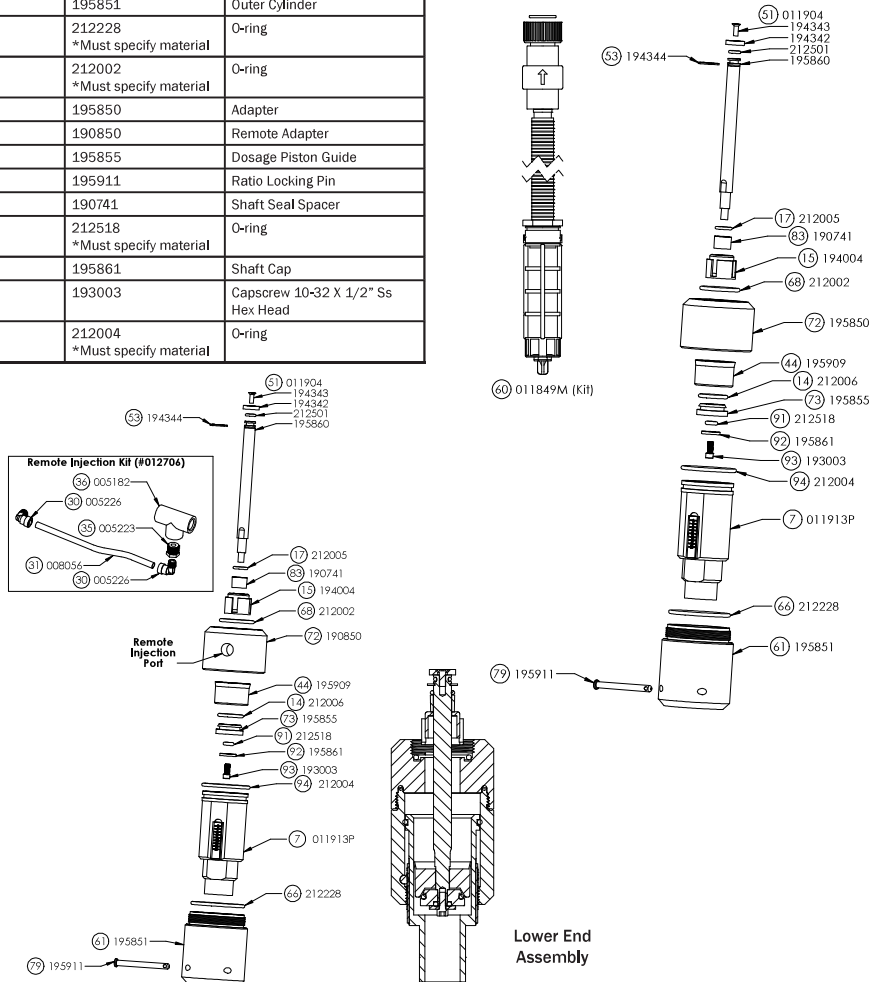

Warranty

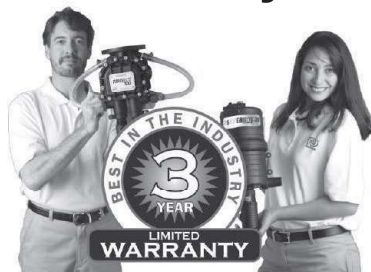

Congratulations on Your Purchase

We make the best and most reliable fluid-driven injectors available. Our warranty provides the best coverage in the industry. Hydro Systems will provide for replacement of all parts proven to be defective in material or workmanship from the date of purchase for the following periods:

3 years	The cover and body
2 years	The motor piston assembly
1 year	The lower end (Chemical pump)

Hydro Systems products are warranted to be free from defects in materials and workmanship for the above time frames. Hydro Systems will at its sole option repair or replace any component that fails in normal use. Any repairs made under warranty shall not extend the initial warranty period.

To Maintain Your Warranty

Your only responsibility is ordinary maintenance - filtering incoming fluid, replacing the O-ring and dosage piston when worn. Seals and O-rings are not covered under the warranty.

This warranty is not valid if the defects are found to be due to the product's misuse, lack of maintenance, fluid

continued...

impurities such as sand or iron, defective installation, freezing, fluid hammer, abuse, unwanted side effects due to the chemicals you choose to inject or service provided by anyone who is not an authorized service provider, Hydro Systems declines any responsibility if the product is not used in compliance with the operating instructions and specifications as indicated in this owner's manual.

Warranty may be void if injector body is disassembled. If you suspect you are having a problem in the motor piston assembly or inside the body please contact Hydro Systems or any authorized repair center to arrange to send the injector in to be evaluated and/or repaired.

IN NO EVENT SHALL Hydro Systems BE LIABLE FOR ANY INCIDENTAL, SPECIAL, INDIRECT, OR CONSEQUENTIAL DAMAGES, WHETHER RESULTING FROM THE USE, MISUSE OR INABILITY TO USE THIS PRODUCT OR FROM DEFECTS IN THE PRODUCT.

There is no warranty expressed or implied relating in any way to products used in conjunction with Hydro Systems.

Hydro Systems or authorized distributor shall not be liable for incidental or consequential damage, such as any economic loss. Hydro Systems retains the exclusive right to repair or replace the product. Such remedy shall be your sole and exclusive remedy for any breach of warranty. There are no warranties, expressed or implied, which extend beyond those described above.

To Return an injector for Warranty or Non-Warranty repair:

See page 3 for Hydro Systems country contact information.

1. Thoroughly flush the injector with water of any chemical and drain. Ensure proper packing for shipment.
2. To EXPEDITE warranty evaluation and repair or non-warranty product repair, please include the following: a copy of the original invoice, serial number of the unit, chemical used, contact information and a Return Authorization (RA) number, contact your country's Hydro Systems Customer Service to obtain.
3. Send freight prepaid and ship to Hydro Systems or your local distributor. For the name of your local distributor or if returning to Hydro Systems, contact your country's Hydro Systems Customer Service.
4. For a WARRANTED injector: upon inspection and determination that the unit has defects in materials or workmanship, the unit will be repaired or replaced at Hydro Systems's option, free of charge and shipped back freight prepaid.
5. For a NON-WARRANTED injector: upon inspection Hydro Systems or a local distributor will call the customer with a repair estimate.